

PLAYSKOOL

33256

OVER 18M-4Y

123
SESAME STREET

Elmo's Cell Phone



Each time you slide open the cell phone, a different character will appear. Press any button to place a "call" to Oscar the Grouch, Ernie or Abby Cadabby.

Note to Consumer:

This toy is packaged in "TRY ME" mode. Slide the Power Switch to "ON" position for the full range of features.

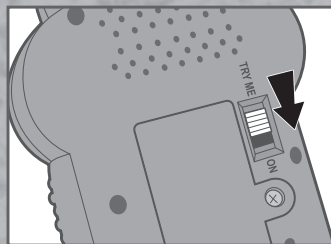

 **x2 BATTERIES INCLUDED**

1.5V AAA or R03 size

Replace with 2 x 1.5V "AAA" or R03 size batteries. Alkaline batteries recommended. Phillips/cross head screwdriver (not included) needed to replace batteries.



Sleep Mode:

After a short time of inactivity, Elmo's Cell Phone will go to sleep mode. Press any button to reactivate.

Troubleshooting:

If Elmo's Cell Phone is unresponsive, or if the sounds become erratic, replace batteries.

TO REPLACE BATTERIES:

Use a Phillips/cross head screwdriver (not included) to loosen screw in battery compartment cover (screw remains attached to cover). Remove cover. Remove and discard old batteries. Replace with fresh 2 x 1.5V "AAA" or R03 size batteries. (Alkaline batteries recommended.) Replace cover and tighten screw.

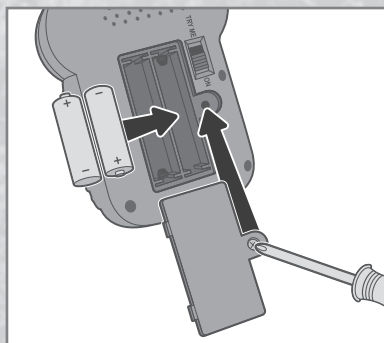

IMPORTANT: BATTERY INFORMATION

⚠ CAUTION:

1. As with all small batteries, the batteries used with this toy should be kept away from small children who still put things in their mouths. If they are swallowed, promptly see a doctor and have the doctor phone (202) 625-3333 collect. If you reside outside the United States, have the doctor call your local poison control center.
2. Always follow the instructions carefully. Use only batteries specified and be sure to insert them correctly by matching the + and - polarity markings.
3. Do not mix old batteries and new batteries or standard (carbon-zinc) with alkaline batteries.
4. Remove exhausted or dead batteries from the product.
5. Remove batteries if product is not to be played with for a long time.
6. Do not short-circuit the supply terminals.
7. Should this product cause, or be affected by, local electrical interference, move it away from other electrical equipment. Reset (switching off and back on again or removing and re-inserting batteries) if necessary.
8. RECHARGEABLE BATTERIES: Do not mix these with any other types of batteries. Always remove from the product before recharging. Recharge batteries under adult supervision. DO NOT RECHARGE OTHER TYPES OF BATTERIES.

FCC STATEMENT

This device complies with Part 15 of the FCC Rules. Operation is subject to the following two conditions: (1) This device may not cause harmful interference, and (2) this device must accept any interference received, including interference that may cause undesired operation.

NOTE: This equipment has been tested and found to comply with the limits for a Class B digital device, pursuant to Part 15 of the FCC Rules. These limits are designed to provide reasonable protection against harmful interference in a residential installation. This equipment generates, uses and can radiate radio frequency energy, and, if not installed and used in accordance with the instructions, may cause harmful interference to radio communications. However, there is no guarantee that interference will not occur in a particular installation. If this equipment does cause harmful interference to radio or television reception, which can be determined by turning the equipment off and on, the user is encouraged to try to correct the interference by one or more of the following measures:

- Reorient or relocate the receiving antenna.
- Increase the separation between the equipment and receiver.
- Consult the dealer or an experienced radio/TV technician for help.

CAUTION: Changes or modifications to this unit not expressly approved by the party responsible for compliance could void the user's authority to operate the equipment.

Learn and play at
SesameStreet.org

Questions? Call 1-800-327-8264

33256/33255 Asst. P/N 7170970000

Product and colors may vary. Retain these instructions for future reference.



® and/or TM® & © 2011 Hasbro. All Rights Reserved. TM & ® denote U.S. Trademarks.

Sesame Workshop®, Sesame Street® and associated characters, trademarks and design elements are owned and licensed by Sesame Workshop.
© 2011 Sesame Workshop. All Rights Reserved.

© 2011 Hasbro. All rights reserved / Tous droits réservés.

Hasbro SA, Route de Courroux 6, 2800 Delemont CH. Hasbro Europe, 2 Roundwood Ave, Stockley Park, Uxbridge, Middlesex, UB11 1AZ, UK.

